

# **City of Scottsbluff, Nebraska**

**Monday, September 21, 2020**

**Regular Meeting**

## **Item Reports2**

**Council to discuss and consider action on the renewal of Lease Agreements with Telecom West, Inc. for their wireless antenna systems on the Airport and Cemetery Water Towers and authorize the Mayor to sign the Agreement.**

**Staff Contact: Rick Kuckkahn, Interim City Manager**

# Agenda Statement

Meeting Date: September 21, 2020

**AGENDA TITLE:** Council to consider the renewal of Lease Agreements with Telecom West, Inc. for their wireless antenna systems on the Airport and Cemetery Water Towers.

**SUBMITTED BY DEPARTMENT/ORGANIZATION:** Public Works

**PRESENTATION BY:** Rick Kuckkahn, Interim City Manager

**SUMMARY EXPLANATION:** Telecom West, Inc. has 2 existing Lease Agreements with the City for renting a portion of the Airport and Cemetery Water Towers where their antennae, cables, hardware and appurtenances are mounted.

The Lease term renewal options read: This LEASE may be renewed for an additional period after the initial term, upon written request by Lessee and written approval by Lessor 30 days prior to expiration of original LEASE.

We have received their written request to extend both Leases for another 2 year term under the same terms and conditions. The Cemetery Tower Agreement includes a rental fee of \$150.00 a month plus 1 internet service connection for the Cemetery administrative building valued at \$75.00. The Airport Tower Agreement includes a rental fee of \$225.00 a month.

**BOARD/COMMISSION RECOMMENDATION:**

**STAFF RECOMMENDATION:** Staff recommends that Council renew these Lease Agreements and authorize the Mayor to execute approval of an additional 2-year term.

---

Resolution <input type="checkbox"/>	Ordinance <input type="checkbox"/>	<b>EXHIBITS</b> Contract <input checked="" type="checkbox"/>	Minutes <input type="checkbox"/>	Plan/Map <input type="checkbox"/>
-------------------------------------	------------------------------------	---	----------------------------------	-----------------------------------

Please provide all visual presentation materials.

Other (specify)  Written request for additional 2 year term.

**NOTIFICATION LIST:** Yes  No  Further Instructions

---

City of Scottsbluff  
Office of the City Manager

Effective date: January 20, 2017

# Telecom West Inc

814 East 3rd St  
PO Box 539  
Alliance NE 69301  
308-762-4072

9/4/2020

City of Scottsbluff  
Water Dept  
2525 Circle Drive  
Scottsbluff, NE 69361

Telecom West INC would like to extend our lease agreement for the Airport water tower space and the Cemetery Water Tower space for another 2 years.

Thank you,



Telecom West INC  
Gerald and Sherrie Leistriz  
814 E 3rd St.  
Alliance, NE 69301  
308-762-4072  
sherrie.leistriz@yahoo.com

The 2-year Lease Agreements for the Airport and Cemetery Water Towers, provide for renewal under the following:

3. Lease Term, b. Renewal Options. This LEASE may be renewed for an additional period after the initial term, upon written request by Lessee and written approval by Lessor 30 days prior to expiration of original LEASE.

The Lessor (City of Scottsbluff) agrees to renew both LEASES under the same terms and conditions for an additional 2-year period beginning 9-30-20.

---

City of Scottsbluff

## LEASE AGREEMENT

THIS LEASE entered into as of this 30th day of September, 2018, by and between the City of Scottsbluff, a Nebraska Municipal Corporation, hereinafter referred to as "LESSOR." and Telecom West Inc., a Nebraska Corporation hereinafter referred to as "LESSEE."

WHEREAS, LESSOR is the owner of a water tower ("water tower"), on a site located in the Airport area at 2100 Airport Road, City of Scottsbluff, State of Nebraska, and

WHEREAS, LESSEE desires to lease from LESSOR a portion of this water tower to enable LESSEE to erect, operate and maintain equipment for a High Speed Wireless Broadband service, consisting of but not limited to six (6) antennae, one (1) directional flat panel and two (2) directional dishes on the existing water tower, owned by the LESSOR, and the construction of appurtenances, cables and hardware, as deemed necessary by LESSEE and approved by LESSOR.

WITNESSETH, that for and in consideration of the mutual covenants contained herein, the LESSOR and LESSEE agree as follows:

## LEASE AGREEMENT

### **1. Definitions.**

Antenna Facilities: The antennae, cables, hardware and other appurtenances installed on LESSOR'S water tower. See Exhibit A.

Water Tower: Water tower site at 2100 Airport Road, Scottsbluff, Nebraska

LESSOR: City of Scottsbluff, Nebraska

LESSEE: Telecom West Inc., a Nebraska Corporation, a High Speed Wireless Broadband Provider.

**2. Leased Premises.** LESSOR hereby leases to LESSEE and LESSEE leases from LESSOR a portion of the water tower, consisting of space on the water tower ("leased premises"). LESSEE intends to locate directional antennae, and sectorial antennae connecting cables and appurtenances. This LEASE is not a franchise agreement, nor is it a permit to use the LESSOR'S rights-of-way. Any such franchise or right-of-way permit must be obtained separately from LESSOR.

### **3. Lease Term.**

**a. Initial Term.** The initial LEASE term (“The Initial Term”) shall commence on 09/30/2018 (“The Commencement Date”). This Initial Term shall terminate and end at 12:00 midnight, local time on 09/30/2020, provided the LEASE has not otherwise been terminated as provided herein.

**b. Renewal Options.** This LEASE may be renewed for an additional period after the initial term, upon written request by LESSEE and written approval by LESSOR, 30 days prior to expiration of original LEASE.

**4. Termination.** In addition to the termination provisions provided for in Paragraph 3, above or elsewhere herein, this LEASE may be terminated, without any penalty or further liability as follows:

**a. LESSEE’S Right of Termination.** Provided LESSEE is not in default hereunder, and shall have paid all rents and sums due and payable to LESSOR pursuant to the terms of this LEASE, the LESSEE shall have the right, in LESSEE’S sole discretion for any reason, to terminate this LEASE at anytime, with or without cause, upon six (6) months prior written notice from LESSEE to LESSOR.

**b. LESSOR’S Right of Termination.** Reciprocally, LESSOR shall have the right to terminate this LEASE at anytime, with or without cause, in LESSOR’S sole discretion, upon six (6) months prior written notice from LESSOR to LESSEE.

**c. Failure of LESSEE to Secure Permits.** It is understood and agreed by the parties hereto that LESSEE’s ability to use the water tower is contingent upon it obtaining all of the certificates, permits and other approvals that may be required by federal, state or local authorities which will permit LESSEE’S use of the water tower as described herein. LESSEE shall use its best efforts to obtain all of the necessary certificates, permits and approvals, which shall be obtained at LESSEE’s sole expense. In the event any such application for permit shall be finally rejected or LESSEE in its reasonable discretion believes such application approval will be too costly, time consuming or there is a reasonable likelihood that said application will be rejected, or any certificate, permit, license or approval issued to LESSEE is canceled or is withdrawn by governmental authority so that LESSEE in its sole discretion will be unable to use the water tower for the use set forth herein, LESSEE shall have the right to terminate this LEASE.

**d. Optional Termination.** This LEASE may be terminated (a); by LESSOR if the LESSOR decides, in its sole discretion and for any reason, to redevelop the water tower and/or discontinue use of the water tower. (b) By LESSOR if it determines, in its sole discretion and for any reason, that the water tower is

structurally unsound or otherwise not suitable for LESSEE's use, including but not limited to consideration of age of the structure, damage or destruction of all or part of the water tower from any source, or factors relating to condition of the water tower; (c) by LESSOR if it determines in its sole discretion that continued use of the water tower by LESSEE is in fact a threat to health, safety or welfare or violates applicable laws or ordinances.

**e. Alteration, Damage or Destruction.** If the water tower or any portion thereof are altered, destroyed or damaged so as to materially hinder effective use of the water tower, through no fault or negligence of LESSEE, LESSEE may elect to terminate this LEASE upon thirty (30) days written notice to LESSOR. In such event, LESSEE shall promptly remove its Antennae Facilities and related equipment from the water tower and shall restore the water tower to the same condition as existed prior to this LEASE. This LEASE (and LESSEE's obligation to pay rent) shall terminate upon LESSEE's fulfillment of the obligations set forth in the preceding sentence, at which termination LESSEE shall be entitled to the reimbursement of any rent prepaid by LESSEE. LESSOR shall have no obligation to repair any damage to any portion of LESSEE's equipment.

**f. Other Termination.** This LEASE may be terminated as otherwise provided herein.

**g. Notice of Termination.** Prior written notification of a parties intent to exercise its right to terminate this LEASE shall be by certified mail, return receipt requested, and shall be effective upon receipt of such notice, as evidenced by the return receipt.

**h. Effect of Termination.** Upon termination, this LEASE shall become null and void and the parties hereto shall have no further obligations, including the payment of rent, except as otherwise provided herein. Upon termination of this LEASE for any reason, LESSEE shall remove its Antennae Facilities and related equipment from the water tower within thirty (30) days of the date of termination, and shall repair any damage to the water tower caused by such equipment, normal wear and tear excepted; all at LESSEE's sole cost and expense. Any such property or facilities, which are not removed by the end of the LEASE term, shall become the property of LESSOR.

**5. Rent.** Upon the "Commencement Date," and throughout the "Initial Term" of the LEASE, the LESSEE shall pay to LESSOR, without notice to or demand from LESSOR and without any right of setoff or deduction, equal monthly rent installments of \$225.00.

**6. Use of Water Tower.** LESSEE is authorized by this LEASE to use the water tower solely for the installation, operation, and maintenance of 6 sectorial antennae, 1 directional flat panel and 2 directional dishes to be located at the top of the water tower. One climate controlled enclosure mounted at the base of the water tower. The LESSEE may use the water tower and the equipment it locates thereon for the transmission, reception and operation and maintenance of High Speed Wireless Broadband Service, and uses incidental thereto in accordance with the terms of this LEASE. This use shall be non-exclusive. LESSEE may not add additional equipment and/or antennas beyond that shown without the approval of the LESSOR. LESSOR reserves the right to require LESSEE to relocate its facilities to another location on the water tower. LESSEE shall complete the relocation of its facilities within thirty (30) days after written notice from LESSOR. The relocation shall be at LESSEE'S expense.

**a. Required licenses and permits.** LESSEE shall, at its expense, comply with all present and future federal, state, and local laws, ordinances, rules and regulations (including laws and ordinances relating to health, radio frequency emissions, other radiation and safety) in connection with the use, operation, maintenance, construction and/or installation of the Antenna Facilities and/or any other permitted activity on the water tower.

**b. Removal of Antenna Facilities.** The LESSEE shall remove all of its Antennae Facilities and other communications equipment from the water tower upon termination of the LEASE. Such removal shall be done in a workmanlike and careful manner and without interference or damage to any other equipment, structures or operations on the water tower, including use of the water tower by LESSOR or any of LESSOR's assignees or lessees. If, however, LESSEE requests permission not to remove all or a portion of the improvements, and LESSOR consents to such non-removal, title to the affected improvements shall thereupon transfer to LESSOR and the same thereafter shall be the sole and entire property of LESSOR, and LESSEE shall be relieved of its duty to otherwise remove same. Upon removal of the improvements, LESSEE shall restore the affected area of the water tower to the reasonable satisfaction of LESSOR. All costs and expenses for the removal and restoration to be performed by LESSEE shall be borne by LESSEE, and LESSEE shall hold LESSOR harmless from any portion thereof.

**7. Installation of Equipment and Leasehold Improvements.** LESSEE shall have the right, at its sole cost and expense, to install, operate and maintain on the water tower, in accordance with good engineering practices and with all applicable FCC rules and regulations, its Antenna Facilities.

**a. Installation according to plan.** LESSEE's installation of all such Antenna Facilities shall be done according to plans approved by LESSOR. Any damage done to the water tower during installation and/or during operations shall be

immediately repaired or replaced at LESSEE's expense and to LESSOR's sole satisfaction.

**8. Equipment Upgrade.** LESSEE may update or replace the Antennae Facilities from time to time with the prior written approval of LESSOR, provided that the replacement facilities are not greater in number or size than the existing facilities and that any change in their location on the water tower is satisfactory to LESSOR.

**9. Maintenance.** LESSEE shall, at its own expense, maintain any Antenna Facilities on or attached to the water tower, in a safe condition, in good repair and in a manner suitable to LESSOR so as not to conflict with the use of the water tower or city property by LESSOR. LESSEE shall not interfere with the use of the water tower, the water tower site, related facilities or other equipment of third parties. LESSEE shall have sole responsibility for the maintenance, repair, and security of its equipment, personal property, Antennae facilities, and leasehold improvements, and shall keep the same in good repair and condition during the LEASE term. LESSEE shall keep the water tower free of debris and anything of a dangerous, noxious or offensive nature or which would create a hazard or undue vibration, heat, noise or interference.

9.a. LESSEE will be responsible for and shall indemnify and hold harmless the LESSOR for any damage caused to LESSOR by LESSEE'S use of the water tower. In addition, LESSEE will be responsible for and pay the costs required to move or temporarily relocate the Antenna Facilities in the event the LESSOR determines to conduct maintenance or repainting of the water tower. In such an event, LESSOR agrees to give LESSEE written notice of the maintenance activity at least thirty (30) days prior to it beginning.

**10. Water Tower Access.** LESSEE, at all times during this LEASE, shall have vehicle ingress and egress to the water tower by means of the existing driveway to the water tower. LESSEE shall have reasonable access to the water tower over the driveway described above in order to install, operate, and maintain its Antennae Facilities. LESSOR shall be allowed and granted access to the water tower at reasonable times to examine and inspect the water tower for safety reasons or to ensure that the LESSEE's covenants are being met.

**11. Utilities.** LESSEE shall, at its expense, separately meter charges for the consumption of electricity and other utilities associated with its use of the water tower and shall timely pay all costs associated therewith.

**12. License Fees.** LESSEE shall pay, as they become due and payable, all fees, charges, taxes and expenses required for licenses and/or permits required for or occasioned by LESSEE's use of the water tower.



**13. Compliance with Statutes, Regulations, and Approvals.** LESSEE's use of the water tower is contingent upon its obtaining all certificates, permits, zoning, and other approvals that may be required by any federal, state or local authority. LESSEE shall erect, maintain and operate its Antennae Facilities in accordance with site standards, state statutes, ordinances, rules and regulations now in effect, or that thereafter may be issued by the Federal Communications Commission, or any other governing bodies.

**14. Interference.**

**a. Interference with LESSOR'S use of water tower or other communications activity.** LESSEE's installation, operation, and maintenance of its Antenna Facilities to include transmission facilities and general use of the water tower, shall not damage or interfere in any way, to include but not limited to intermodulation interference, with LESSOR's use of the water tower or related communications operations to include communications and other LESSOR activities not located on the water tower. If LESSEE'S Antenna Facilities, or any part of LESSEE'S operation, installation or maintenance causes interference, LESSEE shall take all measures reasonably necessary to correct and eliminate the interference. If the interference cannot be eliminated, LESSEE shall immediately cease operating its facility until the interference has been eliminated. If the interference cannot be eliminated within 30 days, LESSOR or LESSEE may terminate this LEASE without penalty or liability to the non-terminating party. LESSOR, at all times during this LEASE, reserves the right to take any action it deems necessary, in its sole discretion, to repair, maintain, alter or improve the water tower in connection with water tower operations as may be necessary, including leasing parts of the water tower to others.

**b. No guarantee of noninterference.** LESSOR does not guarantee to LESSEE noninterference or subsequent noninterference with LESSEE's communications operations. LESSEE'S sole remedy for interference with its operation shall be to terminate this LEASE immediately, without penalty or liability to either party. LESSEE shall have no right to enjoin such interference. In the event any other party except a governmental unit, office or agency requests a lease and/or permission to place any type of additional antenna or transmission facility on the water tower, the procedures of this paragraph shall govern to determine whether such antenna or transmission facility will interfere with LESSEE's transmission operations. If LESSOR receives any such request, LESSOR shall submit a proposal complete with all technical specifications reasonably requested by LESSEE to LESSEE for review for noninterference; however, LESSOR shall not be required to provide LESSEE with any specifications or information claimed to be of a proprietary nature by the third party. The third party shall be responsible for the reasonable cost of preparing the technical specifications for its proposed transmission facility. LESSEE shall have thirty (30) days following receipt of said proposal to make any objections thereto, and failure to make any objection within

said thirty (30) day period shall be deemed consent by LESSEE to the installation of antennas or transmission facilities pursuant to said proposal. If LESSEE gives notice of objection due to interference during such 30 day period and LESSEE's objections are verified by LESSOR to be valid, then LESSOR shall not proceed with such proposal unless LESSOR modifies the proposal in a manner determined, in LESSOR's reasonable judgment, to adequately reduce the interference. In that case, LESSOR may proceed with the proposal. A governmental unit may be allowed to place antennae or other communications facilities on the water tower regardless of potential or actual interference with LESSEE's use, provided however, if LESSEE's use of the water tower is materially affected, LESSEE sole remedy shall be to terminate the LEASE, without penalty or liability to either party. LESSEE shall have no right to enjoin the interference.

**15. Default and LESSOR's Remedies.** It shall be a default if LESSEE fails to make payment of rent as provided herein, or any other sums to LESSOR when due, and does not cure such default within ten (10) days; or if LESSEE defaults in the performance of any other covenant or condition of this LEASE and does not cure such other default within thirty (30) days after written notice from LESSOR specifying the default complained of; or if LESSEE abandons or vacates the water tower; or if LESSEE is adjudicated as bankrupt or makes any assignment for the benefit of creditors; or if LESSEE becomes insolvent or LESSOR reasonably believes itself to be insecure. In the event of a default, LESSOR shall have the right, at its option, in addition to and not exclusive of any other remedy LESSOR may have by operation of law, without any further demand or notice, to re-enter their water tower and eject all persons there from, and declare this LEASE at an end, in which event LESSEE shall immediately remove its Antennae Facilities and related equipment and property. If suit shall be brought by LESSOR for recovery of possession of the leased space on the water tower, for the recovery of any rent or any other amount due under the provisions of this LEASE, or because of the breach of any other covenant, the LESSEE shall pay to the LESSOR all expenses incurred therefore, including reasonable attorney fees.

**16. Cure by LESSOR.** In the event of any default of this LEASE by LESSEE, the LESSOR may at any time, after notice, cure the default for the account of and at the expense of the LESSEE. If LESSOR is compelled to pay or elects to pay any sum of money or to do any act which will require the payment of any sum of money or is compelled to incur any expense, including reasonable attorney fees in instituting, prosecuting or defending any action to enforce the LESSOR's rights under this LEASE, the sums so paid by LESSOR, with all interest, costs and damages shall be deemed to be additional rental and shall be due from the LESSEE to LESSOR on the first day of the month following the incurring of the respective expenses.

## **17. Indemnity and Insurance.**

**a. Disclaimer of Liability:** LESSOR shall not at any time be liable for injury or damage occurring to any person or property from any cause whatsoever arising out of LESSEE's construction, maintenance, repair, use, operation or condition of the water tower or LESSEE's Antennae Facilities.

**b. Indemnification:** LESSEE shall, at its sole cost and expense, indemnify and hold harmless LESSOR and all of LESSOR'S employees, agents, assignees and contractors (hereinafter referred to as "Indemnitees"), from and against:

1. Any and all liability, obligation, damages, penalties, claims, liens, costs, charges, losses and expenses (including, without limitation, reasonable fees and expenses of attorneys, expert witnesses and consultants), which may be imposed upon, incurred by or be asserted against the Indemnitees by reason of or result of the negligence, willful misconduct or any act or omission of LESSEE or its personnel, employees, agents and assignees, and all of its affiliates and subsidiaries, its subcontractors and/or assignees and their respective servants, agents and employees; and agents, contractors or subcontractors, resulting in personal injury, bodily injury, sickness, disease or death to any person or damage to, loss of or destruction of tangible or intangible property, libel, slander, invasion of privacy and unauthorized use of any trademark, trade name, copyright, patent, service mark or any other right of any person, firm or corporation, which may arise out of or be in any way connected with LESSEE'S construction, installation, operation, maintenance, use or condition of the water tower or LESSEE's Antennae Facilities or the LESSEE's failure to comply with any federal, state or local statute, ordinance or regulation or are claimed to arise out of or be connected with, the performance of this LEASE.

2. Any and all liabilities, obligations, damages, penalties, claims, liens, costs, charges, losses and expenses (including, without limitation, reasonable fees and expenses of attorneys, expert witnesses and other consultants), which are imposed upon, incurred by or asserted against the Indemnitees by reason of any claim or lien arising out of work, labor, materials or supplies provided or supplied to LESSEE, its contractors or subcontractors, for the installation, construction, operation, maintenance or use of the water tower or LESSEE's Antennae Facilities.

It is agreed as a specific element of consideration of this LEASE that the LESSEE'S indemnity of LESSOR shall apply notwithstanding the joint, concurring or contributory or comparative fault or negligence of the LESSOR or any third party and, further notwithstanding any theory of law including, but not limited to, a characterization of the LESSOR'S or any third party's joint, concurring or contributory or comparative fault or negligence as either

passive or active in nature; provided, however, that the LESSEE'S obligation hereunder shall not include amounts attributable to the fault or negligence of the LESSOR. Nothing in this section shall be deemed to impose liability on the LESSEE to indemnify the LESSOR for loss when the LESSOR'S negligence or other actionable fault is the sole cause of loss. With respect to the LESSOR'S rights as set forth herein, the LESSEE expressly waives all statutory defenses, including, but not limited to, those under workers compensation, contribution, comparative fault or similar statutes to the extent said defenses are inconsistent with or would defeat the duty of the LESSEE to indemnify the LESSOR.

**b. Defense of Indemnitees:** In the event any action or proceeding shall be brought against the Indemnitees by reason of any matter for which the Indemnitees are indemnified hereunder, LESSEE shall, upon notice from any of the Indemnitees, at LESSEE's sole cost and expense, resist and defend the same with legal counsel mutually selected by LESSEE and LESSOR.

**c. Notice, Cooperation and Expenses:** LESSOR shall give LESSEE prompt notice of the making of any claim or the commencement of any action, suit or other proceeding covered by the provisions of this paragraph. Nothing herein shall be deemed to prevent LESSOR from cooperating with LESSEE and participating in the defense of any litigation by LESSOR's own counsel. LESSEE shall pay all expenses incurred by LESSOR in response to any such actions, suits or proceedings. These expenses shall include all out-of-pocket expenses such as attorney fees and shall also include the reasonable value of any services rendered by the LESSOR's attorney, and the actual expenses of LESSOR's agents, employees or expert witnesses, and disbursements and liabilities assumed by LESSOR in connection with such suits, actions or proceedings but shall not include attorneys' fees for services that are unnecessarily duplicative of services provided LESSOR by LESSEE. If LESSEE requests LESSOR to assist it in such defense then LESSEE shall pay all expenses incurred by LESSOR in response thereto, including defending itself with regard to any such actions, suits or proceedings. These expenses shall include all out-of-pocket expenses such as attorney fees and shall also include the costs of any services rendered by the LESSOR's attorney, and the actual expenses of LESSOR's agents, employees or expert witnesses, and disbursements and liabilities assumed by LESSOR in connection with such suits, actions or proceedings.

**d. Assumption of Risk:** LESSEE undertakes and assumes for its officers, agents, affiliates, contractors and subcontractors and employees (collectively "LESSEE" for the purpose of this section), all risk of dangerous conditions, if any, on or about the water tower, and LESSEE hereby agrees to indemnify and hold harmless the Indemnitees against and from any claim asserted or liability imposed upon the Indemnitees for personal injury or property damage to any person (other than from Indemnitee's gross negligence) arising out of the LESSEE's installation, operation,

maintenance, condition or use of the water tower or LESSEE's Antennae Facilities or LESSEE's failure to comply with any federal, state or local statute, ordinance or regulation

**f. Insurance:** During the term of the LEASE, LESSEE shall maintain, or cause to be maintained, in full force and effect and at its sole cost and expense, the following types and limits of insurance, and will include the LESSOR as an additional insured on the policy: Also, the policy cannot be cancelled until after reasonable 30 days notice prior to cancellation is given to LESSOR:

i. Worker's compensation insurance meeting applicable statutory requirements and employer's liability insurance with minimum limits of One Hundred Thousand Dollars (\$100,000) for each accident.

ii. Comprehensive commercial general liability insurance with minimum limits of One Million Dollars (\$1,000,000) as the combined single limit for each occurrence of bodily injury, personal injury and property damage. The policy shall provide blanket contractual liability insurance for all written contracts, and shall include coverage for products and completed operations liability, independent contractor's liability; coverage for property damage from perils of explosion, collapse or damage to underground utilities, commonly known as XCU coverage.

iii. Automobile liability insurance covering all owned, hired, and nonowned vehicles in use by LESSEE, its employees and agents, with personal protection insurance and property protection insurance.

**g. Insurance Companies:** All insurance shall be effected under valid and enforceable policies, insured by insurers licensed to do business by the State of Nebraska or surplus line carriers on the State of Nebraska Insurance Commissioner's approved list of companies qualified to do business in the State. All insurance carriers and surplus line carriers shall be rated A+ or better by A.M. Best Company.

**h. Contractors:** LESSEE shall require that each and every one of its contractors and their subcontractors who perform work on the water tower to carry, in full force and effect, workers' compensation, comprehensive public liability and automobile liability insurance coverage of the type which LESSEE is required to obtain under the terms of this paragraph with appropriate limits of insurance.

**i. Review of Limits:** Once during each calendar year during the term of this LEASE, LESSOR may review the insurance coverage to be carried by LESSEE. If LESSOR determines that higher limits of coverage are necessary to protect the interests of LESSOR or the Additional Insured's, LESSEE shall be so notified and

shall obtain the additional limits of insurance, at its sole cost and expense. LESSEE shall furnish LESSOR a certificate of insurance, indicating all coverage, at signing of this LEASE.

**18. Hazardous Substance Indemnification.** LESSEE represents and warrants that its use of the water tower will not generate any hazardous substance, and it will not store, dispose nor transport any hazardous substance to or over the water tower. LESSEE further agrees to hold LESSOR harmless from and indemnify LESSOR against any release of any such hazardous substance and any damage, loss, or expense or liability resulting from such release including all attorneys' fees, costs and penalties incurred as a result thereof except any release caused by the negligence of LESSOR, its employees or agents. "Hazardous substance" shall be interpreted broadly to mean any substance or material defined or designated as hazardous or toxic waste, hazardous or toxic material, hazardous or toxic or radioactive substance, or other similar term by any federal, state or local environmental law, regulation or rule presently in effect or promulgated in the future, as such laws, regulations or rules may be amended from time to time; and it shall be interpreted to include, but not be limited to, any substance which after release into the environment will or may reasonably be anticipated to cause sickness, death or disease.

**19. Acceptance of Leased Premises.** By taking possession of the leased premises, LESSEE accepts the water tower in the condition existing as of the Commencement Date. LESSOR makes no representation or warranty with respect to the condition of the water tower and LESSOR shall not be liable for any latent or patent defect in the water tower.

**20. Assignment.** LESSEE may not assign this LEASE or sublet the leased premises without the prior written consent of LESSOR. Nothing in this LEASE shall preclude LESSOR from leasing other space for communications equipment to any person or entity, which may be in competition with LESSEE, or any other party.

**21. Successors and Assigns.** This LEASE shall be binding upon and inure to the benefit of the parties, their respective successors, personal representatives and assigns.

**22. Non-Waiver.** Failure of LESSOR to insist on strict performance of any of the conditions, covenants, terms or provisions of this LEASE or to exercise any of its rights hereunder shall not waive such rights, but LESSOR shall have the rights to enforce such rights at any time and take such action as might be lawful or authorized hereunder, either in law or equity. The receipt of any sum paid by LESSEE to LESSOR after a breach of this LEASE shall not be deemed a waiver of such breach unless expressly set forth in writing.

**23. Miscellaneous.**

a. LESSOR and LESSEE represent that each, respectively, has full right, power, and authority to execute this LEASE.

b. This LEASE constitutes the entire agreement and understanding of the parties and supersedes all offers, negotiations, and other agreements of any kind. There are no representations or understandings of any kind not set forth herein. Any modification of or amendment to this LEASE must be in writing and executed by both parties.

c. This LEASE shall be construed in accordance with the laws of the State of Nebraska.

d. If any term of this LEASE is found to be void or invalid, such invalidity shall not affect the remaining terms of this LEASE, which shall continue in full force and effect.

This LEASE was executed as of the date first set forth above.



**LESSOR:**

City of Scottsbluff

By: \_\_\_\_\_

**LESSEE:**

Telecom West Inc.

By: \_\_\_\_\_

*Derald Seibert*  
09-10-18

Scottsbluff Airport Water Tower

North

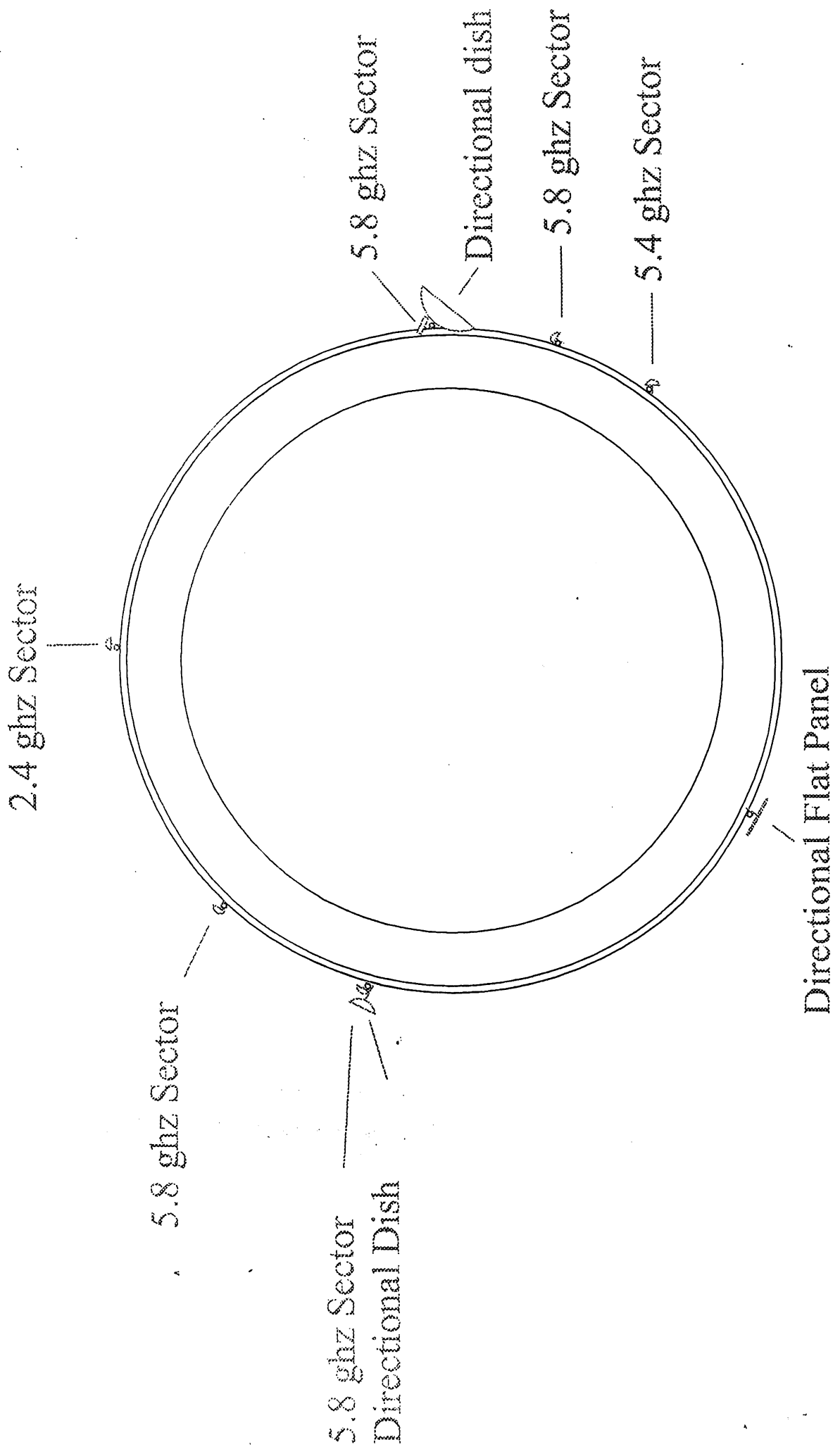



# Telecom West Inc



814 East 3rd St  
PO Box 539  
Alliance NE 69301  
308-762-4072

9/4/2020

City of Scottsbluff  
Water Dept  
2525 Circle Drive  
Scottsbluff, NE 69361

Telecom West INC would like to extend our lease agreement for the Airport water tower space and the Cemetery Water Tower space for another 2 years.

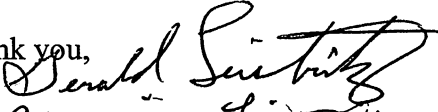
Thank you,

  
  
Telecom West INC  
Gerald and Sherrie Leistritz  
814 E 3rd St.  
Alliance, NE 69301  
308-762-4072  
sherrie.leistritz@yahoo.com

The 2-year Lease Agreements for the Airport and Cemetery Water Towers, provide for renewal under the following:

3. Lease Term, b. Renewal Options. This LEASE may be renewed for an additional period after the initial term, upon written request by Lessee and written approval by Lessor 30 days prior to expiration of original LEASE.

The Lessor (City of Scottsbluff) agrees to renew both LEASES under the same terms and conditions for an additional 2-year period beginning 9-30-20.

---

City of Scottsbluff

## **LEASE AGREEMENT**

THIS LEASE entered into as of this 30th day of September, 2018, by and between the City of Scottsbluff, a Nebraska Municipal Corporation, hereinafter referred to as “LESSOR.” and Telecom West Inc., a Nebraska Corporation hereinafter referred to as “LESSEE.”

WHEREAS, LESSOR is the owner of a water tower (“water tower”), on a site located at 513 E 42<sup>nd</sup> St., City of Scottsbluff, State of Nebraska, and

WHEREAS, LESSEE desires to lease from LESSOR a portion of this water tower to enable LESSEE to erect, operate and maintain equipment for a High Speed Wireless Broadband service, consisting of but not limited to six (6) antennae and one (1) directional dish on the existing water tower, owned by the LESSOR, and the construction of appurtenances, cables and hardware, as deemed necessary by LESSEE and approved by LESSOR.

WITNESSETH, that for and in consideration of the mutual covenants contained herein, the LESSOR and LESSEE agree as follows:

## **LEASE AGREEMENT**

### **1. Definitions.**

Antenna Facilities: The antennae, cables, hardware and other appurtenances installed on LESSOR’S water tower. See Exhibit A.

Water Tower: Water tower site at 513 E. 42<sup>nd</sup> St., Scottsbluff, Nebraska

LESSOR: City of Scottsbluff, Nebraska

LESSEE: Telecom West Inc., a Nebraska Corporation, a High Speed Wireless Broadband Provider.

**2. Leased Premises.** LESSOR hereby leases to LESSEE and LESSEE leases from LESSOR a portion of the water tower, consisting of space on the water tower (“leased premises”). LESSEE intends to locate directional antennae, and sectorial antennae connecting cables and appurtenances. This LEASE is not a franchise agreement, nor is it a permit to use the LESSOR’S rights-of-way. Any such franchise or right-of-way permit must be obtained separately from LESSOR.

### **3. Lease Term.**

**a. Initial Term.** The initial LEASE term (“The Initial Term”) shall commence on 09/30/2018 (“The Commencement Date”). This Initial Term shall terminate and end at 12:00 midnight, local time on 09/30/2020, provided the LEASE has not otherwise been terminated as provided herein.

**b. Renewal Options.** This LEASE may be renewed for an additional period after the initial term, upon written request by LESSEE and written approval by LESSOR, 30 days prior to expiration of original LEASE.

**4. Termination.** In addition to the termination provisions provided for in Paragraph 3, above or elsewhere herein, this LEASE may be terminated, without any penalty or further liability as follows:

**a. LESSEE’S Right of Termination.** Provided LESSEE is not in default hereunder, and shall have paid all rents and sums due and payable to LESSOR pursuant to the terms of this LEASE, the LESSEE shall have the right, in LESSEE’S sole discretion for any reason, to terminate this LEASE at anytime, with or without cause, upon six (6) months prior written notice from LESSEE to LESSOR.

**b. LESSOR’S Right of Termination.** Reciprocally, LESSOR shall have the right to terminate this LEASE at anytime, with or without cause, in LESSOR’S sole discretion, upon six (6) months prior written notice from LESSOR to LESSEE.

**c. Failure of LESSEE to Secure Permits.** It is understood and agreed by the parties hereto that LESSEE’s ability to use the water tower is contingent upon it obtaining all of the certificates, permits and other approvals that may be required by federal, state or local authorities which will permit LESSEE’S use of the water tower as described herein. LESSEE shall use its best efforts to obtain all of the necessary certificates, permits and approvals, which shall be obtained at LESSEE’s sole expense. In the event any such application for permit shall be finally rejected or LESSEE in its reasonable discretion believes such application approval will be too costly, time consuming or there is a reasonable likelihood that said application will be rejected, or any certificate, permit, license or approval issued to LESSEE is canceled or is withdrawn by governmental authority so that LESSEE in its sole discretion will be unable to use the water tower for the use set forth herein, LESSEE shall have the right to terminate this LEASE.

**d. Optional Termination.** This LEASE may be terminated (a); by LESSOR if the LESSOR decides, in its sole discretion and for any reason, to redevelop the water tower and/or discontinue use of the water tower. (b) By LESSOR if it determines, in its sole discretion and for any reason, that the water tower is

structurally unsound or otherwise not suitable for LESSEE's use, including but not limited to consideration of age of the structure, damage or destruction of all or part of the water tower from any source, or factors relating to condition of the water tower; (c) by LESSOR if it determines in its sole discretion that continued use of the water tower by LESSEE is in fact a threat to health, safety or welfare or violates applicable laws or ordinances.

**e. Alteration, Damage or Destruction.** If the water tower or any portion thereof are altered, destroyed or damaged so as to materially hinder effective use of the water tower, through no fault or negligence of LESSEE, LESSEE may elect to terminate this LEASE upon thirty (30) days written notice to LESSOR. In such event, LESSEE shall promptly remove its Antennae Facilities and related equipment from the water tower and shall restore the water tower to the same condition as existed prior to this LEASE. This LEASE (and LESSEE's obligation to pay rent) shall terminate upon LESSEE's fulfillment of the obligations set forth in the preceding sentence, at which termination LESSEE shall be entitled to the reimbursement of any rent prepaid by LESSEE. LESSOR shall have no obligation to repair any damage to any portion of LESSEE's equipment.

**f. Other Termination.** This LEASE may be terminated as otherwise provided herein.

**g. Notice of Termination.** Prior written notification of a parties intent to exercise its right to terminate this LEASE shall be by certified mail, return receipt requested, and shall be effective upon receipt of such notice, as evidenced by the return receipt.

**h. Effect of Termination.** Upon termination, this LEASE shall become null and void and the parties hereto shall have no further obligations, including the payment of rent, except as otherwise provided herein. Upon termination of this LEASE for any reason, LESSEE shall remove its Antennae Facilities and related equipment from the water tower within thirty (30) days of the date of termination, and shall repair any damage to the water tower caused by such equipment, normal wear and tear excepted; all at LESSEE's sole cost and expense. Any such property or facilities, which are not removed by the end of the LEASE term, shall become the property of LESSOR.

**5. Rent.** Upon the "Commencement Date," and throughout the "Initial Term" of the LEASE, the LESSEE shall pay to LESSOR, without notice to or demand from LESSOR and without any right of setoff or deduction, equal monthly rent installments of \$150.00, and wireless internet service to The Cemetery Administration Building, located at 4009 5<sup>th</sup> Ave., Equivalent to \$75.00 per month. Provided the LEASE is not otherwise terminated.

**6. Use of Water Tower.** LESSEE is authorized by this LEASE to use the water tower solely for the installation, operation, and maintenance of 6 sectorial antennae, and 1 directional dish to be located at the top of the water tower. One climate controlled enclosure mounted at the base of the water tower. The LESSEE may use the water tower and the equipment it locates thereon for the transmission, reception and operation and maintenance of High Speed Wireless Broadband Service, and uses incidental thereto in accordance with the terms of this LEASE. This use shall be non-exclusive. LESSEE may not add additional equipment and/or antennas beyond that shown without the approval of the LESSOR. LESSOR reserves the right to require LESSEE to relocate its facilities to another location on the water tower. LESSEE shall complete the relocation of its facilities within thirty (30) days after written notice from LESSOR. The relocation shall be at LESSEE'S expense.

**a. Required licenses and permits.** LESSEE shall, at its expense, comply with all present and future federal, state, and local laws, ordinances, rules and regulations (including laws and ordinances relating to health, radio frequency emissions, other radiation and safety) in connection with the use, operation, maintenance, construction and/or installation of the Antenna Facilities and/or any other permitted activity on the water tower.

**b. Removal of Antenna Facilities.** The LESSEE shall remove all of its Antennae Facilities and other communications equipment from the water tower upon termination of the LEASE. Such removal shall be done in a workmanlike and careful manner and without interference or damage to any other equipment, structures or operations on the water tower, including use of the water tower by LESSOR or any of LESSOR's assignees or lessees. If, however, LESSEE requests permission not to remove all or a portion of the improvements, and LESSOR consents to such non-removal, title to the affected improvements shall thereupon transfer to LESSOR and the same thereafter shall be the sole and entire property of LESSOR, and LESSEE shall be relieved of its duty to otherwise remove same. Upon removal of the improvements, LESSEE shall restore the affected area of the water tower to the reasonable satisfaction of LESSOR. All costs and expenses for the removal and restoration to be performed by LESSEE shall be borne by LESSEE, and LESSEE shall hold LESSOR harmless from any portion thereof.

**7. Installation of Equipment and Leasehold Improvements.** LESSEE shall have the right, at its sole cost and expense, to install, operate and maintain on the water tower, in accordance with good engineering practices and with all applicable FCC rules and regulations, its Antenna Facilities.

**a. Installation according to plan.** LESSEE's installation of all such Antenna Facilities shall be done according to plans approved by LESSOR. Any damage done to the water tower during installation and/or during operations shall be

immediately repaired or replaced at LESSEE's expense and to LESSOR's sole satisfaction.

**8. Equipment Upgrade.** LESSEE may update or replace the Antennae Facilities from time to time with the prior written approval of LESSOR, provided that the replacement facilities are not greater in number or size than the existing facilities and that any change in their location on the water tower is satisfactory to LESSOR.

**9. Maintenance.** LESSEE shall, at its own expense, maintain any Antenna Facilities on or attached to the water tower, in a safe condition, in good repair and in a manner suitable to LESSOR so as not to conflict with the use of the water tower or city property by LESSOR. LESSEE shall not interfere with the use of the water tower, the water tower site, related facilities or other equipment of third parties. LESSEE shall have sole responsibility for the maintenance, repair, and security of its equipment, personal property, Antennae facilities, and leasehold improvements, and shall keep the same in good repair and condition during the LEASE term. LESSEE shall keep the water tower free of debris and anything of a dangerous, noxious or offensive nature or which would create a hazard or undue vibration, heat, noise or interference.

9.a. LESSEE will be responsible for and shall indemnify and hold harmless the LESSOR for any damage caused to LESSOR by LESSEE'S use of the water tower. In addition, LESSEE will be responsible for and pay the costs required to move or temporarily relocate the Antenna Facilities in the event the LESSOR determines to conduct maintenance or repainting of the water tower. In such an event, LESSOR agrees to give LESSEE written notice of the maintenance activity at least thirty (30) days prior to it beginning.

**10. Water Tower Access.** LESSEE, at all times during this LEASE, shall have vehicle ingress and egress to the water tower by means of the existing driveway to the water tower. LESSEE shall have reasonable access to the water tower over the driveway described above in order to install, operate, and maintain its Antennae Facilities. LESSOR shall be allowed and granted access to the water tower at reasonable times to examine and inspect the water tower for safety reasons or to ensure that the LESSEE's covenants are being met.

**11. Utilities.** LESSEE shall, at its expense, separately meter charges for the consumption of electricity and other utilities associated with its use of the water tower and shall timely pay all costs associated therewith.

**12. License Fees.** LESSEE shall pay, as they become due and payable, all fees, charges, taxes and expenses required for licenses and/or permits required for or occasioned by LESSEE's use of the water tower.

**13. Compliance with Statutes, Regulations, and Approvals.** LESSEE's use of the water tower is contingent upon its obtaining all certificates, permits, zoning, and other approvals that may be required by any federal, state or local authority. LESSEE shall erect, maintain and operate its Antennae Facilities in accordance with site standards, state statutes, ordinances, rules and regulations now in effect, or that thereafter may be issued by the Federal Communications Commission, or any other governing bodies.

**14. Interference.**

**a. Interference with LESSOR'S use of water tower or other communications activity.** LESSEE's installation, operation, and maintenance of its Antenna Facilities to include transmission facilities and general use of the water tower, shall not damage or interfere in any way, to include but not limited to intermodulation interference, with LESSOR's use of the water tower or related communications operations to include communications and other LESSOR activities not located on the water tower. If LESSEE'S Antenna Facilities, or any part of LESSEE'S operation, installation or maintenance causes interference, LESSEE shall take all measures reasonably necessary to correct and eliminate the interference. If the interference cannot be eliminated, LESSEE shall immediately cease operating its facility until the interference has been eliminated. If the interference cannot be eliminated within 30 days, LESSOR or LESSEE may terminate this LEASE without penalty or liability to the non-terminating party. LESSOR, at all times during this LEASE, reserves the right to take any action it deems necessary, in its sole discretion, to repair, maintain, alter or improve the water tower in connection with water tower operations as may be necessary, including leasing parts of the water tower to others.

**b. No guarantee of noninterference.** LESSOR does not guarantee to LESSEE noninterference or subsequent noninterference with LESSEE's communications operations. LESSEE'S sole remedy for interference with its operation shall be to terminate this LEASE immediately, without penalty or liability to either party. LESSEE shall have no right to enjoin such interference. In the event any other party except a governmental unit, office or agency requests a lease and/or permission to place any type of additional antenna or transmission facility on the water tower, the procedures of this paragraph shall govern to determine whether such antenna or transmission facility will interfere with LESSEE's transmission operations. If LESSOR receives any such request, LESSOR shall submit a proposal complete with all technical specifications reasonably requested by LESSEE to LESSEE for review for noninterference; however, LESSOR shall not be required to provide LESSEE with any specifications or information claimed to be of a proprietary nature by the third party. The third party shall be responsible for the reasonable cost of preparing the technical specifications for its proposed transmission facility. LESSEE shall have thirty (30) days following receipt of said proposal to make any objections thereto, and failure to make any objection within

said thirty (30) day period shall be deemed consent by LESSEE to the installation of antennas or transmission facilities pursuant to said proposal. If LESSEE gives notice of objection due to interference during such 30 day period and LESSEE's objections are verified by LESSOR to be valid, then LESSOR shall not proceed with such proposal unless LESSOR modifies the proposal in a manner determined, in LESSOR's reasonable judgment, to adequately reduce the interference. In that case, LESSOR may proceed with the proposal. A governmental unit may be allowed to place antennae or other communications facilities on the water tower regardless of potential or actual interference with LESSEE's use, provided however, if LESSEE's use of the water tower is materially affected, LESSEE sole remedy shall be to terminate the LEASE, without penalty or liability to either party. LESSEE shall have no right to enjoin the interference.

**15. Default and LESSOR's Remedies.** It shall be a default if LESSEE fails to make payment of rent as provided herein, or any other sums to LESSOR when due, and does not cure such default within ten (10) days; or if LESSEE defaults in the performance of any other covenant or condition of this LEASE and does not cure such other default within thirty (30) days after written notice from LESSOR specifying the default complained of; or if LESSEE abandons or vacates the water tower; or if LESSEE is adjudicated as bankrupt or makes any assignment for the benefit of creditors; or if LESSEE becomes insolvent or LESSOR reasonably believes itself to be insecure. In the event of a default, LESSOR shall have the right, at its option, in addition to and not exclusive of any other remedy LESSOR may have by operation of law, without any further demand or notice, to re-enter their water tower and eject all persons there from, and declare this LEASE at an end, in which event LESSEE shall immediately remove its Antennae Facilities and related equipment and property. If suit shall be brought by LESSOR for recovery of possession of the leased space on the water tower, for the recovery of any rent or any other amount due under the provisions of this LEASE, or because of the breach of any other covenant, the LESSEE shall pay to the LESSOR all expenses incurred therefore, including reasonable attorney fees.

**16. Cure by LESSOR.** In the event of any default of this LEASE by LESSEE, the LESSOR may at any time, after notice, cure the default for the account of and at the expense of the LESSEE. If LESSOR is compelled to pay or elects to pay any sum of money or to do any act which will require the payment of any sum of money or is compelled to incur any expense, including reasonable attorney fees in instituting, prosecuting or defending any action to enforce the LESSOR's rights under this LEASE, the sums so paid by LESSOR, with all interest, costs and damages shall be deemed to be additional rental and shall be due from the LESSEE to LESSOR on the first day of the month following the incurring of the respective expenses.



## **17. Indemnity and Insurance.**

**a. Disclaimer of Liability:** LESSOR shall not at any time be liable for injury or damage occurring to any person or property from any cause whatsoever arising out of LESSEE's construction, maintenance, repair, use, operation or condition of the water tower or LESSEE's Antennae Facilities.

**b. Indemnification:** LESSEE shall, at its sole cost and expense, indemnify and hold harmless LESSOR and all of LESSOR'S employees, agents, assignees and contractors (hereinafter referred to as "Indemnitees"), from and against:

1. Any and all liability, obligation, damages, penalties, claims, liens, costs, charges, losses and expenses (including, without limitation, reasonable fees and expenses of attorneys, expert witnesses and consultants), which may be imposed upon, incurred by or be asserted against the Indemnitees by reason of or result of the negligence, willful misconduct or any act or omission of LESSEE or its personnel, employees, agents and assignees, and all of its affiliates and subsidiaries, its subcontractors and/or assignees and their respective servants, agents and employees; and agents, contractors or subcontractors, resulting in personal injury, bodily injury, sickness, disease or death to any person or damage to, loss of or destruction of tangible or intangible property, libel, slander, invasion of privacy and unauthorized use of any trademark, trade name, copyright, patent, service mark or any other right of any person, firm or corporation, which may arise out of or be in any way connected with LESSEE'S construction, installation, operation, maintenance, use or condition of the water tower or LESSEE's Antennae Facilities or the LESSEE's failure to comply with any federal, state or local statute, ordinance or regulation or are claimed to arise out of or be connected with, the performance of this LEASE.

2. Any and all liabilities, obligations, damages, penalties, claims, liens, costs, charges, losses and expenses (including, without limitation, reasonable fees and expenses of attorneys, expert witnesses and other consultants), which are imposed upon, incurred by or asserted against the Indemnitees by reason of any claim or lien arising out of work, labor, materials or supplies provided or supplied to LESSEE, its contractors or subcontractors, for the installation, construction, operation, maintenance or use of the water tower or LESSEE's Antennae Facilities.

It is agreed as a specific element of consideration of this LEASE that the LESSEE'S indemnity of LESSOR shall apply notwithstanding the joint, concurring or contributory or comparative fault or negligence of the LESSOR or any third party and, further notwithstanding any theory of law including, but not limited to, a characterization of the LESSOR'S or any third party's joint, concurring or contributory or comparative fault or negligence as either

passive or active in nature; provided, however, that the LESSEE'S obligation hereunder shall not include amounts attributable to the fault or negligence of the LESSOR. Nothing in this section shall be deemed to impose liability on the LESSEE to indemnify the LESSOR for loss when the LESSOR'S negligence or other actionable fault is the sole cause of loss. With respect to the LESSOR'S rights as set forth herein, the LESSEE expressly waives all statutory defenses, including, but not limited to, those under workers compensation, contribution, comparative fault or similar statutes to the extent said defenses are inconsistent with or would defeat the duty of the LESSEE to indemnify the LESSOR.

**b. Defense of Indemnitees:** In the event any action or proceeding shall be brought against the Indemnitees by reason of any matter for which the Indemnitees are indemnified hereunder, LESSEE shall, upon notice from any of the Indemnitees, at LESSEE's sole cost and expense, resist and defend the same with legal counsel mutually selected by LESSEE and LESSOR.

**c. Notice, Cooperation and Expenses:** LESSOR shall give LESSEE prompt notice of the making of any claim or the commencement of any action, suit or other proceeding covered by the provisions of this paragraph. Nothing herein shall be deemed to prevent LESSOR from cooperating with LESSEE and participating in the defense of any litigation by LESSOR's own counsel. LESSEE shall pay all expenses incurred by LESSOR in response to any such actions, suits or proceedings. These expenses shall include all out-of-pocket expenses such as attorney fees and shall also include the reasonable value of any services rendered by the LESSOR's attorney, and the actual expenses of LESSOR's agents, employees or expert witnesses, and disbursements and liabilities assumed by LESSOR in connection with such suits, actions or proceedings but shall not include attorneys' fees for services that are unnecessarily duplicative of services provided LESSOR by LESSEE. If LESSEE requests LESSOR to assist it in such defense then LESSEE shall pay all expenses incurred by LESSOR in response thereto, including defending itself with regard to any such actions, suits or proceedings. These expenses shall include all out-of-pocket expenses such as attorney fees and shall also include the costs of any services rendered by the LESSOR's attorney, and the actual expenses of LESSOR's agents, employees or expert witnesses, and disbursements and liabilities assumed by LESSOR in connection with such suits, actions or proceedings.

**d. Assumption of Risk:** LESSEE undertakes and assumes for its officers, agents, affiliates, contractors and subcontractors and employees (collectively "LESSEE" for the purpose of this section), all risk of dangerous conditions, if any, on or about the water tower, and LESSEE hereby agrees to indemnify and hold harmless the Indemnitees against and from any claim asserted or liability imposed upon the Indemnitees for personal injury or property damage to any person (other than from Indemnitee's gross negligence) arising out of the LESSEE's installation, operation,

maintenance, condition or use of the water tower or LESSEE's Antennae Facilities or LESSEE's failure to comply with any federal, state or local statute, ordinance or regulation

**f. Insurance:** During the term of the LEASE, LESSEE shall maintain, or cause to be maintained, in full force and effect and at its sole cost and expense, the following types and limits of insurance, and will include the LESSOR as an additional insured on the policy: Also, the policy cannot be cancelled until after reasonable 30 days notice prior to cancellation is given to LESSOR:

i. Worker's compensation insurance meeting applicable statutory requirements and employer's liability insurance with minimum limits of One Hundred Thousand Dollars (\$100,000) for each accident.

ii. Comprehensive commercial general liability insurance with minimum limits of One Million Dollars (\$1,000,000) as the combined single limit for each occurrence of bodily injury, personal injury and property damage. The policy shall provide blanket contractual liability insurance for all written contracts, and shall include coverage for products and completed operations liability, independent contractor's liability; coverage for property damage from perils of explosion, collapse or damage to underground utilities, commonly known as XCU coverage.

iii. Automobile liability insurance covering all owned, hired, and nonowned vehicles in use by LESSEE, its employees and agents, with personal protection insurance and property protection insurance.

**g. Insurance Companies:** All insurance shall be effected under valid and enforceable policies, insured by insurers licensed to do business by the State of Nebraska or surplus line carriers on the State of Nebraska Insurance Commissioner's approved list of companies qualified to do business in the State. All insurance carriers and surplus line carriers shall be rated A+ or better by A.M. Best Company.

**h. Contractors:** LESSEE shall require that each and every one of its contractors and their subcontractors who perform work on the water tower to carry, in full force and effect, workers' compensation, comprehensive public liability and automobile liability insurance coverage of the type which LESSEE is required to obtain under the terms of this paragraph with appropriate limits of insurance.

**i. Review of Limits:** Once during each calendar year during the term of this LEASE, LESSOR may review the insurance coverage to be carried by LESSEE. If LESSOR determines that higher limits of coverage are necessary to protect the interests of LESSOR or the Additional Insured's, LESSEE shall be so notified and

shall obtain the additional limits of insurance, at its sole cost and expense. LESSEE shall furnish LESSOR a certificate of insurance, indicating all coverage, at signing of this LEASE.

**18. Hazardous Substance Indemnification.** LESSEE represents and warrants that its use of the water tower will not generate any hazardous substance, and it will not store, dispose nor transport any hazardous substance to or over the water tower. LESSEE further agrees to hold LESSOR harmless from and indemnify LESSOR against any release of any such hazardous substance and any damage, loss, or expense or liability resulting from such release including all attorneys' fees, costs and penalties incurred as a result thereof except any release caused by the negligence of LESSOR, its employees or agents. "Hazardous substance" shall be interpreted broadly to mean any substance or material defined or designated as hazardous or toxic waste, hazardous or toxic material, hazardous or toxic or radioactive substance, or other similar term by any federal, state or local environmental law, regulation or rule presently in effect or promulgated in the future, as such laws, regulations or rules may be amended from time to time; and it shall be interpreted to include, but not be limited to, any substance which after release into the environment will or may reasonably be anticipated to cause sickness, death or disease.

**19. Acceptance of Leased Premises.** By taking possession of the leased premises, LESSEE accepts the water tower in the condition existing as of the Commencement Date. LESSOR makes no representation or warranty with respect to the condition of the water tower and LESSOR shall not be liable for any latent or patent defect in the water tower.

**20. Assignment.** LESSEE may not assign this LEASE or sublet the leased premises without the prior written consent of LESSOR. Nothing in this LEASE shall preclude LESSOR from leasing other space for communications equipment to any person or entity, which may be in competition with LESSEE, or any other party.

**21. Successors and Assigns.** This LEASE shall be binding upon and inure to the benefit of the parties, their respective successors, personal representatives and assigns.

**22. Non-Waiver.** Failure of LESSOR to insist on strict performance of any of the conditions, covenants, terms or provisions of this LEASE or to exercise any of its rights hereunder shall not waive such rights, but LESSOR shall have the rights to enforce such rights at any time and take such action as might be lawful or authorized hereunder, either in law or equity. The receipt of any sum paid by LESSEE to LESSOR after a breach of this LEASE shall not be deemed a waiver of such breach unless expressly set forth in writing.

**23. Miscellaneous.**

a. LESSOR and LESSEE represent that each, respectively, has full right, power, and authority to execute this LEASE.

b. This LEASE constitutes the entire agreement and understanding of the parties and supersedes all offers, negotiations, and other agreements of any kind. There are no representations or understandings of any kind not set forth herein. Any modification of or amendment to this LEASE must be in writing and executed by both parties.

c. This LEASE shall be construed in accordance with the laws of the State of Nebraska.

d. If any term of this LEASE is found to be void or invalid, such invalidity shall not affect the remaining terms of this LEASE, which shall continue in full force and effect.

This LEASE was executed as of the date first set forth above.



**LESSOR:**

City of Scottsbluff

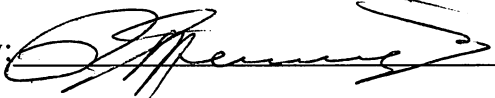
By: 

**LESSEE:**

Telecom West Inc.

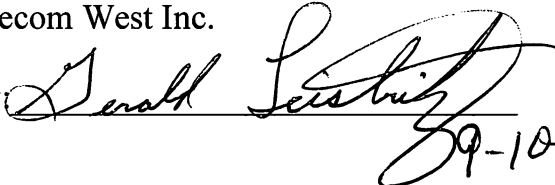
By:   
09-10-18

# Scottsbluff Cemetary Water Tower

North

EXHIBIT A

