



City of Grand Island

Tuesday, December 20, 2011

Council Session

Item G7

**#2011-366 - Approving Acquisition of Utility Easement - West of
Locust Street, and North of Schimmer Drive - Hooker Brothers
Sand & Gravel**

This item relates to the aforementioned Public Hearing item E-2.

Staff Contact: Tim Luchsinger

RESOLUTION 2011-366

WHEREAS, a public utility easement is required by the City of Grand Island, from Hooker Brothers Sand and Gravel, Inc., to survey, construct, inspect, maintain, repair, replace, relocate, extend, remove, and operate thereon, public utilities and appurtenances, including lines and transformers; and;

WHEREAS, a public hearing was held on December 20, 2011, for the purpose of discussing the proposed acquisition of an easement located in Hall County, Nebraska; and more particularly described as follows:

Commencing at the southeast corner of the Southeast Quarter (SE1/4) Section Thirty Three (33), Township Eleven (11) North, Range Nine (9) West; thence northerly along the easterly line of said Southeast Quarter (SE1/4), a distance of one thousand five hundred thirty eight and thirty one hundredths(1,538.31) feet; thence deflecting left 88°35'01" and running westerly along the centerline of an existing easement described in Document 200000822 recorded in the Register of Deeds Office, Hall County, Nebraska, a distance of two hundred forty four and thirty hundredths (244.30) feet to the ACTUAL Point of Beginning; thence deflecting left 30°31'03" and running southwesterly, a distance of one hundred thirty (130.0) feet to the point of termination.

The above-described easement and right-of-way containing 0.060 acres, more or less, as shown on the plat dated 11/30/2011, marked Exhibit "A", attached hereto and incorporated herein by reference,

NOW, THEREFORE, BE IT RESOLVED BY THE MAYOR AND COUNCIL OF THE CITY OF GRAND ISLAND, NEBRASKA, that the City of Grand Island be, and hereby is, authorized to acquire a public utility easement from Hooker Brothers Sand and Gravel, Inc., on the above-described tract of land.

- - -

Adopted by the City Council of the City of Grand Island, Nebraska, December 20, 2011.

Jay Vavricek, Mayor

Attest:

RaNae Edwards, City Clerk

Approved as to Form	☐ _____
December 14, 2011	☐ City Attorney

NE 1/4, SE 1/4
SEC. 33-T11N-R9W

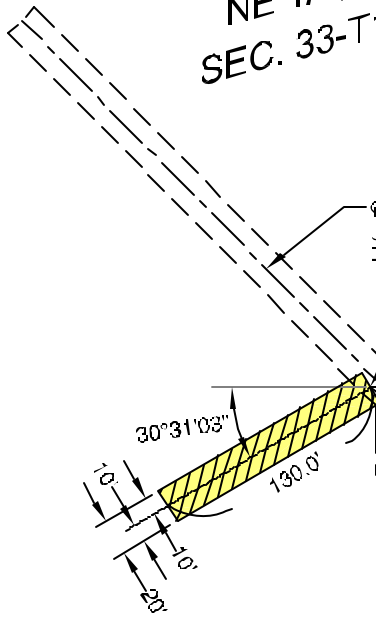

EXISTING 20'
UTILITY EASEMENT-
DOC. #200000822

POINT OF
BEGINNING

244.30'

TRACT OF LAND
DESCRIBED IN
DOC. #200500690

WEST R-O-W LINE-
LOCUST STREET

208.71'

1/16 SECTION LINE

SECTION LINE
STREET
88°35'01"
LOCUST

1,538.31'

EASTERLY LINE- SE 1/4,
SECTION 33-T11N-R9W

SE 1/4, SE 1/4
SEC. 33-T11N-R9W

SE CORNER- SE 1/4,
SECTION 33-T11N-R9W

SCHIMMER DRIVE

SECTION LINE



LEGEND

 INDICATES 20' WIDE
UTILITY EASEMENT

CITY OF
GRAND ISLAND
UTILITIES DEPARTMENT

EXHIBIT "A"

DRN BY: K.J.M.	SCALE: 1"= 100'
DATE: 11/30/2011	FILE: SX 33.11.9