



City of Grand Island

Tuesday, December 20, 2011

Council Session

Item E2

Public Hearing Concerning Acquisition of Utility Easement - West of Locust Street, and North of Schimmer Drive - Hooker Brothers Sand & Gravel

Staff Contact: Tim Luchsinger

Council Agenda Memo

From: Robert H. Smith, Asst. Utilities Director
Meeting: December 20, 2011
Subject: Acquisition of Utility Easement – Just Northwest of the Intersection of Schimmer Drive and Locust Street – Hooker Brothers Sand and Gravel, Inc.
Item #'s: E-2 & G-7
Presenter(s): Timothy Luchsinger, Utilities Director

Background

Nebraska State Law requires that acquisition of property must be approved by City Council. The Utilities Department needs to acquire an easement relative to the property of Hooker Brothers Sand & Gravel, Inc., located just to the north and west of Schimmer Drive and Locust Street, in the City of Grand Island, Hall County, in order to have access to install, upgrade, maintain, and repair power appurtenances, including lines and transformers.

Discussion

This easement will be used to install underground electrical conduit cable and a pad-mounted transformer to provide 3-Phase service to a new building located on the property.

Alternatives

It appears that the Council has the following alternatives concerning the issue at hand. The Council may:

1. Make a motion to approve
2. Refer the issue to a Committee
3. Postpone the issue to future date
4. Take no action on the issue

Recommendation

City Administration recommends that the Council approve the resolution for the acquisition of the easement for one dollar (\$1.00).

Sample Motion

Move to approve acquisition of the Utility Easement.

NE 1/4, SE 1/4
SEC. 33-T11N-R9W

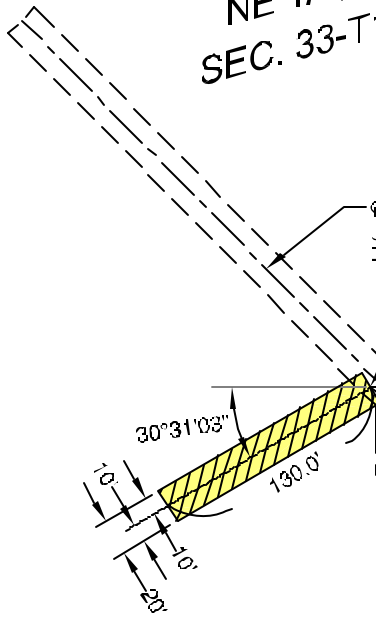

EXISTING 20'
UTILITY EASEMENT-
DOC. #200000822

POINT OF
BEGINNING

244.30'

TRACT OF LAND
DESCRIBED IN
DOC. #200500690

WEST R-O-W LINE-
LOCUST STREET

208.71'

1/16 SECTION LINE

SECTION LINE
STREET
88°35'01"
LOCUST

1,538.31'

EASTERLY LINE- SE 1/4,
SECTION 33-T11N-R9W

SE 1/4, SE 1/4
SEC. 33-T11N-R9W

SE CORNER- SE 1/4,
SECTION 33-T11N-R9W

SCHIMMER DRIVE

SECTION LINE



LEGEND

 INDICATES 20' WIDE
UTILITY EASEMENT

CITY OF
GRAND ISLAND
UTILITIES DEPARTMENT

EXHIBIT "A"

DRN BY: K.J.M.	SCALE: 1"= 100'
DATE: 11/30/2011	FILE: SX 33.11.9