



City of Grand Island

Tuesday, February 24, 2015

Council Session

Item G-8

#2015-47 - Approving Increase to the City's Share of the US Highway 34 Improvements from US Highway 281 to South Locust Street – NDOR Project No. STP 34-4(126); Control No. 41994

Staff Contact: John Collins, P.E. - Public Works Director

Council Agenda Memo

From: Terry Brown PE, Assistant Public Works Director

Meeting: February 24, 2015

Subject: Approving Increase to the City's Share of the US Highway 34 Improvements from US Highway 281 to South Locust Street – NDOR Project No. STP 34-4(126); Control No. 41994

Item #'s: G-8

Presenter(s): John Collins PE, Public Works Director

Background

On February 28, 2012 the City Council approved the agreement between the City and Nebraska Department of Roads (NDOR) for the improvements to US Highway 34 from US Highway 281 to South Locust Street.

Improvements to this stretch of roadway consisted of the following:

- Concrete Repair, as necessary;
- Milling and resurfacing the existing roadway and shoulders with asphaltic concrete;
- Widening the existing roadway to add left-turn lanes at the intersection with Blaine Street;
- New roadway lighting for the left-turn lanes;
- Widening of the Wood River Bridge between Garland and Blaine Street, with new guardrail installed;
- Removal and replacement of the Wood River overflow bridge just west of Blaine Street with a concrete box culvert; and
- Culverts under US Highway 34 will be extended between Blaine Street and Catfish Avenue.

The improvements to US Highway 34 that require City participation begin approximately 300' west of De Ann Road and continue east to the west side of South Locust Street. The City of Grand Island will pay 50% of the preliminary engineering, construction and construction engineering costs for this portion of the project.

The total construction contract was awarded to Werner Construction, Inc. by NDOR in the amount of \$2,333,693.90. The total construction costs for the section requiring the City's participation is \$200,498.01. After the contract was awarded, the City's share had increased from the estimated amount in the original project agreement of \$124,889.00 to \$129,204.98 due to engineering costs and contingencies. This increase was approved by City Council through Resolution No. 2012-326 on November 13, 2012.

Additional work became necessary once the project got underway. An existing twin culvert pipe under US Highway 34 located approximately 1600 feet west of Locust Street was discovered to have a collapsed section, resulting in a cavity under the pavement. Due to the age and deterioration of the culvert pipe, it was decided to replace the existing pipe with a new concrete box culvert. The City's participation for the cost of the culvert replacement is \$14,625.52, which is 50% of the cost for the portion of culvert replacement under the south pavement lanes.

With engineering and project contingencies the City's share for the project increased from \$129,204.98 to \$146,058.50.

Discussion

The US Highway 34 project was completed on November 15, 2013 by Werner Construction, Inc. of Hastings, Nebraska under the direction of the Nebraska Department of Roads (NDOR).

Final City share costs of such project are \$317,825.67, which the City is 50% responsible for.

- Preliminary Engineering - \$36,471.80
 - Construction Engineering - \$20,841.03
 - Construction - \$260,512.84
- Total City Share Project Cost = \$317,825.67

To date the City has paid a total of \$146,058.50 of the \$158,912.84 responsibility.

Alternatives

It appears that the Council has the following alternatives concerning the issue at hand. The Council may:

1. Move to approve
2. Refer the issue to a Committee
3. Postpone the issue to future date
4. Take no action on the issue

Recommendation

City Administration recommends that the Council approve the increase of the City's share for the US Highway 34 Improvements from US Highway 281 to South Locust Street with the Nebraska Department of Roads, for a total amount of \$158,912.84.

Sample Motion

Move to approve the resolution.

INVOICE

TO: CITY OF GRAND ISLAND
 C/O CITY CLERK
 PO BOX 1968
 GRAND ISLAND NE 68802

Billing Address:
 Nebraska Department of Roads
 c/o Controller Division
 1500 Hwy 2
 PO Box 94759
 Lincoln NE 68509-4759

DATE
 01-12-2015

ACCOUNT NUMBER
 G7500

INVOICE NUMBER
 0633268

COST DESCRIPTION

COST

PROJECT NO. STP 34-4(126)
 CONTROL NO. 41994
 AGREEMENT NO. XL1215
 US-281 - LOCUST ST

SEE ATTACHED FOR DETAILS

AMOUNT DUE THIS INVOICE \$ 12,854.34

12,854.34

QUESTIONS, CONTACT MARY GOGGINS AT 402-479-4305.

PREPARED BY:
 M GOGGINS

DESCRIPTION:
 STP 34-4(126)

PAY THIS AMOUNT
 12,854.34

DETACH THIS PORTION AND RETURN WITH A PAYMENT

Make checks payable to & Mail to:

Nebraska Department of Roads
 c/o Controller Division
 PO Box 94759
 Lincoln NE 68509-4759

GRAND ISLAND/CITY OF

CUSTOMER NAME

01-12-2015

DATE OF INVOICE

TERMS

This amount is due upon receipt of this invoice

INVOICE NUMBER
 0633268

ACCOUNT NUMBER
 G7500

AMOUNT
 12,854.34

INVOICE SUPPORT DETAIL

Responsible Party: City of Grand Island
Project No. STP 34-4(126)
Control No. 41994
Agreement No. XL1215
Expenses Thru: January 6, 2015
Description: US-281 - Locust St, Grand Island
Invoice: 0633268

	Total Expenses	City Funding Percent	City Costs Share
Work Phase			
Preliminary Engineering:			
NDOR Expenses to Date	34,142.44	50%	17,071.22
Consultant - VK1128 HDR Engineering, Inc.	✓2,329.36	50%	1,164.69 ✓
Construction:			
Werner Construction, Inc. Federal/City	260,512.84	50%	130,256.42
Construction Engineering:			
NDOR Expenses to Date	20,841.03	50%	10,420.52
Total City Cost Share			158,912.85
Less Previous Invoices			(146,058.50)
Total Due this invoice			12,854.34 ✓

NOTE: NDOR expenses include labor and operating costs.

GRAND ISLAND

HALL COUNTY
NEBRASKA

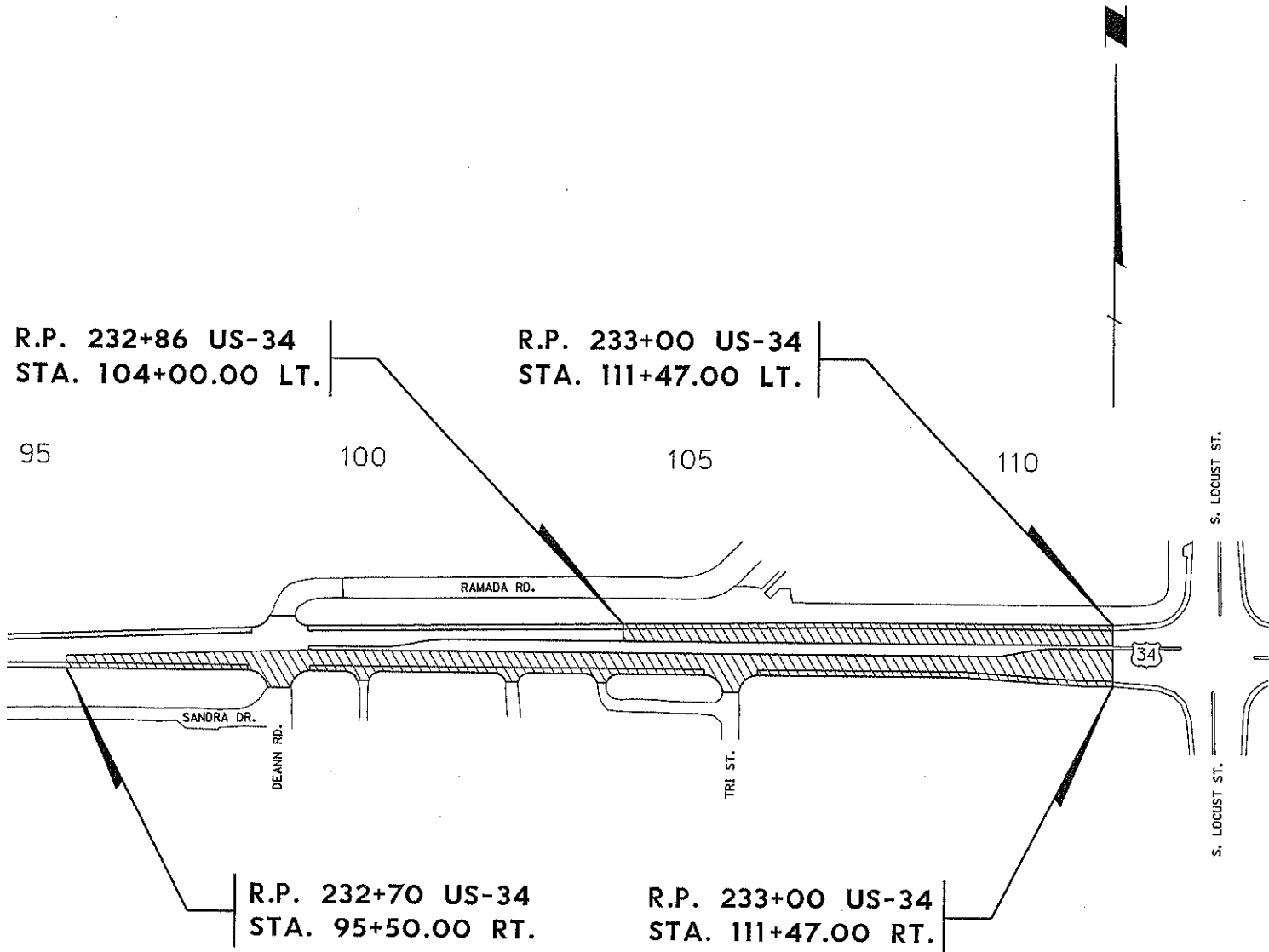

CITY PARTICIPATION 50% 

34-4(126)

C.N. 41994

EXHIBIT "E"

RESOLUTION 2015-47

WHEREAS, the Grand Island City Council approved Resolution No. 2012-48 on February 28, 2012, which provided for the City to share in the cost of improving US Highway 34 from US Highway 281 to South Locust Street in the estimated amount of \$124,889.00; and

WHEREAS, by Resolution No. 2012-326 on November 13, 2013 City Council approved an increase to the City share for such project for a revised total amount of \$129,204.98; and

WHEREAS, by Resolution No. 2013-266 on August 13, 2013 City Council approved an increase to the City share for such project for a revised total amount of \$146,058.50; and

WHEREAS, such project was completed on November 15, 2013 by Werner Construction, Inc. of Hastings, Nebraska under the direction of the Nebraska Department of Roads (NDOR) for a final City share cost of \$317,825.67, which the City is 50% responsible for.

NOW, THEREFORE, BE IT RESOLVED BY THE MAYOR AND COUNCIL OF THE CITY OF GRAND ISLAND, NEBRASKA, that the City's total share of \$158,912.84 for such roadway improvements is hereby approved.

- - -

Adopted by the City Council of the City of Grand Island, Nebraska, February 24, 2015.

Jeremy L. Jensen, Mayor

Attest:

RaNae Edwards, City Clerk

Approved as to Form	☒ _____
February 20, 2015	☒ City Attorney