



City of Grand Island

Tuesday, August 27, 2002

Council Session

Item E3

Public Hearing on Acquisition of Public Utility Easements for Sanitary Sewer Project 2002-S-5

Acquisition of two public utility easements located near Shoemaker Elementary School, is required in order to have access to install, upgrade, maintain, and repair public sanitary sewer mains. It is appropriate to solicit public comment. The action item is contained under the Consent Agenda.

Staff Contact: Steve Riehle, City Engineer/Public Works Director

SHOEMAKER SCHOOL

SCHOOL DISTRICT #38

S.W. COR.
S.1/2,S.E.1/4
SEC. 14-11-10

PT. S.W.1/4,S.E.1/4

SEC. 14-11-10

ACTUAL FT. OF BEGINNING
239.91'

COUNTRY

31

PRAIRIE RIDGE LANE

32 MEADOWS

34

SUB.

HIGHWAY

OLDE

POTASH



SCHOOL - PERMANENT EASEMENT



EXHIBIT "A"

SHOEMAKER SCHOOL

SCHOOL DISTRICT #38

COUNTRY

31

PRAIRIE RIDGE LANE

PT. S.W.1/4, S.E.1/4

32 MEADOWS

SEC. 14-11-10

SUB.

34

HIGHWAY

OLD

POTASH

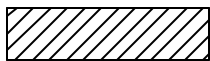
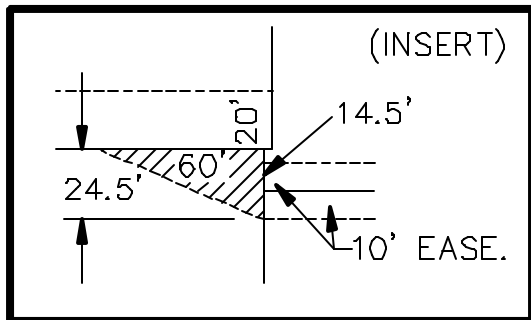

KUSZAK - PERMANENT EASEMENT



EXHIBIT "A"

CITY OF GRAND ISLAND
PUBLIC WORKS DEPARTMENT

DATE: 7-15-02
DRN BY: P.E.S.
SCALE: 1"=400'

KUSZAK
PERMANENT EASEMENT